

National Aeronautics and
Space Administration

HESSI

Spacecraft Model

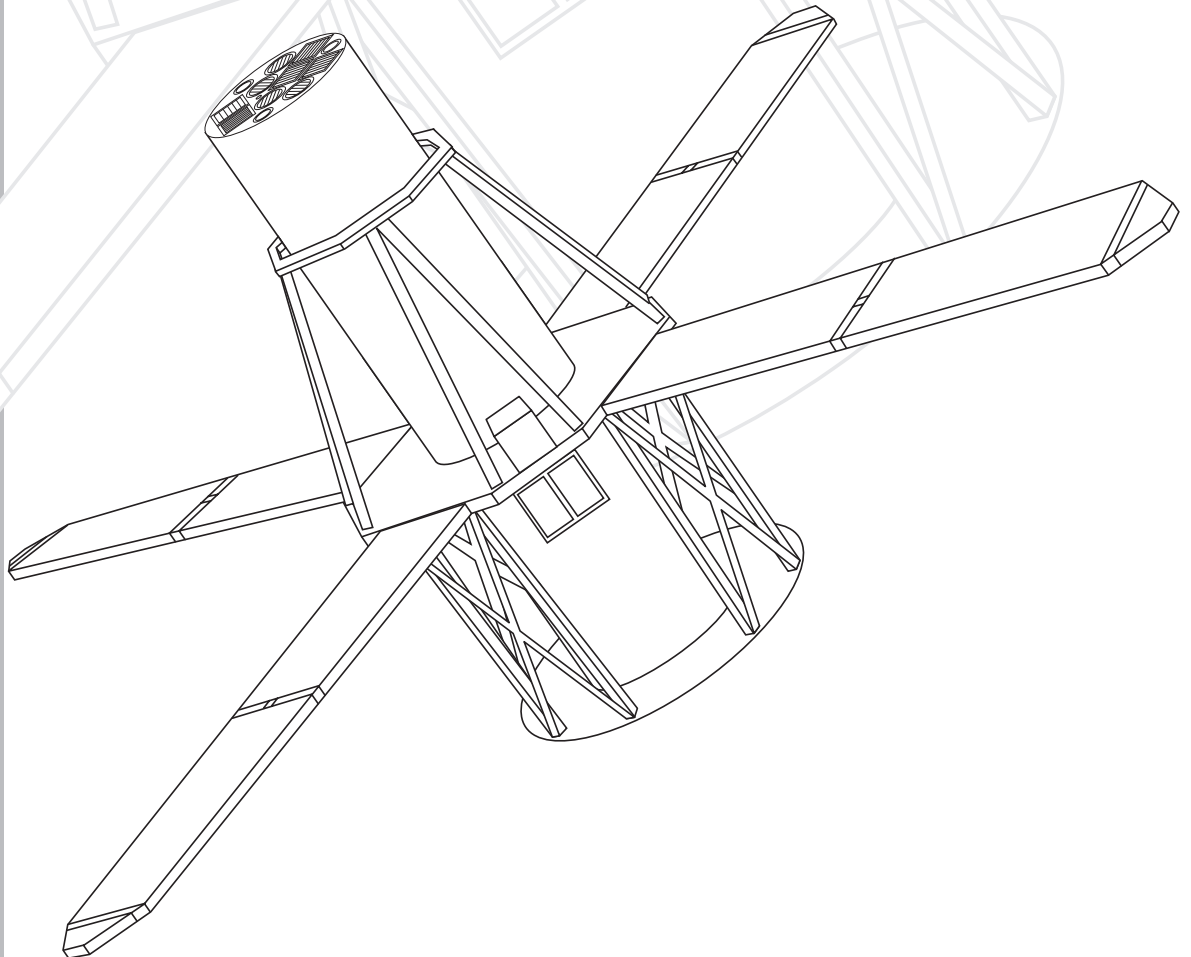

The HESSI Mission

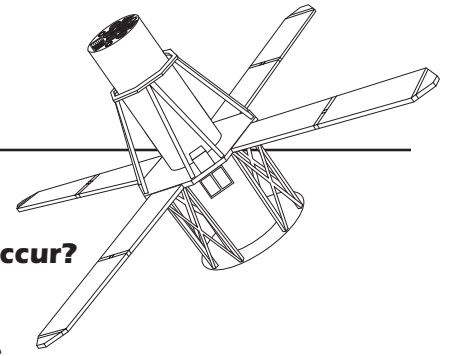

What is HESSI?

The acronym, HESSI, stands for the High Energy Solar Spectroscopic Imager. HESSI is a NASA mission proposed by astrophysicists who study the Sun. Their goal is to learn more about the basic physical processes that occur in solar flares. Teams of astrophysicists and engineers worked together to decide what kinds of observations HESSI would make and what kinds of scientific instrumentation would be required. The HESSI teams will achieve their goal by making "color" pictures of solar flares in X rays and gamma rays.

What is a Solar Flare?

Solar flares are the biggest explosions in the solar system! A solar flare occurs when magnetic energy that builds up in the solar atmosphere is suddenly released. Charged particles, such as electrons, protons, and heavier ions, are accelerated to such high energies that some are traveling at almost the speed of light. Some of these charged particles travel away from the Sun along magnetic field lines. Others move towards the surface of the Sun and emit X rays and gamma rays as they slow down. Also, gas in the solar atmosphere is heated to temperatures as high as 100 million degrees Celsius. This heated gas emits X rays as well. Flares produce all forms of electromagnetic radiation, from radio waves and visible light to X rays and gamma rays.

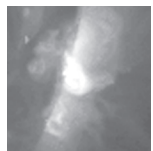

How does HESSI work?

A sundial helps us tell time by having sunlight cast a shadow of an upright object (called a gnomon) onto a horizontal dial. The position of the shadow changes during the day as the Earth rotates. Similarly, HESSI obtains pictures of solar flares using X rays and gamma rays to cast shadows of pairs of metal grids onto detectors. The HESSI detectors, placed below the telescope, measure the numbers and energies of the transmitted X-ray and gamma-ray photons and their variations with time as the spacecraft rotates. This information is transmitted to the ground, where HESSI scientists use it in their computers to make pictures of flares as seen in X rays and gamma rays.



IMPORTANT WARNING: Never look directly at the Sun!

Permanent damage to your eyes could result from looking at the Sun, even during an eclipse!

Where do Flares occur?

Flares occur in the solar atmosphere. The solar atmosphere starts at the photosphere, where the visible light from the Sun originates. It extends through the intermediate layer called the chromosphere to the outermost layer called the corona. The gas in the corona normally has a temperature of a few million degrees. Inside a flare, the temperature typically reaches 10 to 20 million degrees, and can be as high as 100 million degrees Celsius.

How often do Flares occur?

The frequency of flares varies with the Sun's eleven-year cycle. When the solar cycle is at a minimum, very few flares occur. As the Sun approaches the maximum part of its cycle, they begin to occur more and more frequently. The current solar cycle is expected to reach its maximum in the year 2000. HESSI is scheduled to be launched in the summer of 2000 and will observe flares for three years while solar activity is high.

Why will HESSI observe Solar Flares in X rays and gamma rays?

Specialized scientific instruments are used to observe the radiation emitted during a flare. The radio and visible emissions from flares can be observed with telescopes on Earth. Energetic emissions such as X rays and gamma rays require telescopes located in space because these emissions do not penetrate the Earth's atmosphere. High energy X rays and gamma rays carry the most direct information available about the energetic particle activity in flares.

Why study Solar Flares?

The biggest flares are as powerful as billions of hydrogen bombs exploding at the same time! We still don't know what triggers them or how they release so much energy in such a short time. Solar flares have a direct effect on the Earth's upper atmosphere. For instance, long distance radio communications can be disrupted by the effect of flares on the Earth's ionosphere. In addition, energetic particles accelerated in solar flares that escape into interplanetary space are dangerous to astronauts outside the protection of the Earth's magnetic field and to electronic

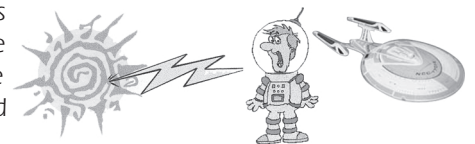

instruments in space. Understanding solar flares can aid in understanding energetic events throughout the Universe.

Instructions on how to assemble the High Energy Solar Spectroscopic Imager **HESSI**

For teachers and students (grades 5-8)

**This publication is in the Public Domain and is not protected by copyright.
Permission for duplication is not required.**

This model is designed to help students understand the operation and objectives of HESSI.

Throughout the assembly of this model, students will encounter the different phases of development and assembly of the spacecraft. The objectives are:

- To develop and understand the purpose of each part.
- To see clearly how all the parts fit together.
- To learn about the Sun and Solar Flares.
- To work in teams to accomplish the above objectives.

The tools needed for this project are the following:

- A pair of scissors
- Rubber Cement
- Scotch tape
- Paperclips (4)

Cutouts included in this assembly booklet:

- Telescope (1)
- Top Grid Plate (1)
- Bottom Grid Plate (1)
- Detector Housing (1)
- Detector Assembly Top Plate (1)
- Detector Assembly Bottom Plate (1)
- Solar Panels (4)
- Support Plate (1)
- Honeycomb Deck (1)
- Struts (16)
- Cross Members (4)
- Top Structure (1)
- Electronic Modules
 - Battery Box (1)
 - Instrument Data Processing Unit (IDPU) (1)
 - Spacecraft Electronic Module (SEM) (1)
 - Solid-State Recorder Box (1)
- Antennas (2)
- Fine Sun Sensor (1)

In order to build the spirit of teamwork, we suggest the classroom be divided into four teams - each with precise tasks to accomplish. Here is a suggestion for the team names and their assignments:

Team	Tasks
Design	Color the Spacecraft
Astrophysics	Build the Telescope and Detector Assembly
Electrical Engineering	Build the Solar Panels, Electronic Modules, Antennas, and Fine Sun Sensor
Structural Engineering	Build the Supports, Struts and Cross Members

Once all the parts are built, a group made up of selected members from each team will assemble the spacecraft.

Assembly

HELPFUL HINT:

For best results when using rubber cement, apply the rubber cement to both contact surfaces on the model. Allow the rubber cement to dry about 2 minutes. When the two dried areas make contact, the bond is stronger than if you join the two parts while the rubber cement is wet.

Design Team

Task: Color the spacecraft.

Visit one of the HESSI web sites (see pg. 20) for appropriate colors. Otherwise, color the Solar Panels dark blue and the remaining parts gold. Remember not to color on the areas of the parts that are shaded in gray. These areas are for application of rubber cement.

Astrophysics Team

Task: Build the Telescope and Detector Assembly.

Telescope

- 1 Cut out the Telescope, pg. 15, and roll it into a cylindrical shape.
- 2 Apply some rubber cement on the shaded area and the opposite contact surface (edge) and roll the piece into a cylinder.
- 3 Allow the opposite edge of the cylinder to overlap the shaded area.
- 4 Press the two edges firmly together.
- 5 Cut out the Top Grid Plate, pg. 17.
- 6 Fold the shaded area inward and make a cover for the cylinder with the grids on the top.
- 7 Hold the Grid Plate in place by applying some rubber cement on the shaded areas.
- 8 Repeat steps 5, 6, and 7 for the Bottom Plate.

Note: The layout on the bottom of the telescope has to be the mirror image of the layout on the top cover, but you do not see the details of the grids on the bottom cover.

Detector Assembly

- 9 Repeat steps 1-8 using the Detector components. Use the Detector Housing instead of the Telescope and Detector Plates instead of the Grid Plates to cover the top and bottom of the cylinder.

Electrical Engineering Team

Task: Build the Solar Panels and the Electronic Modules.

Solar Panels (4)

- 1 Cut out a Solar Panel, pg. 9 or 11.
- 2 Fold along the dashed lines to form a thin box.
- 3 Apply rubber cement on the shaded area and opposite contact surface and glue together.
- 4 Repeat steps 1-4 for all four Solar Panels.

Electronic Modules (4)

- 6 Cut out all the Electronic Modules, including the Battery Box, pg. 13.
- 7 Following the dotted lines, fold the modules into box shapes.
- 8 Apply some rubber cement on the shaded areas and glue together.

Antennas (2) and Fine Sun Sensor (1)

- 1 Cut out the Antennas and Fine Sun Sensor, pg. 13.
- 2 Fold them into wedge shaped boxes.
- 3 Apply rubber cement.
- 4 Fold down the tabs and square section on the top, as can be seen in Photo 4.
- 5 Glue the tabs to the inside of the box.

Structural Engineering Team

Task: Build the Supports, Struts, Cross Members and Top Structure.

Honeycomb Deck

- 1 Cut out the Honeycomb Deck, pg. 7.
- 2 Cut out the inside circle.
- 3 Fold along the dotted lines 90 degrees inward.
- 4 Apply rubber cement on the shaded areas and glue together.
- 5 Cut out the Support Plate, pg. 3.

Continued on pg. 19

Cross Members

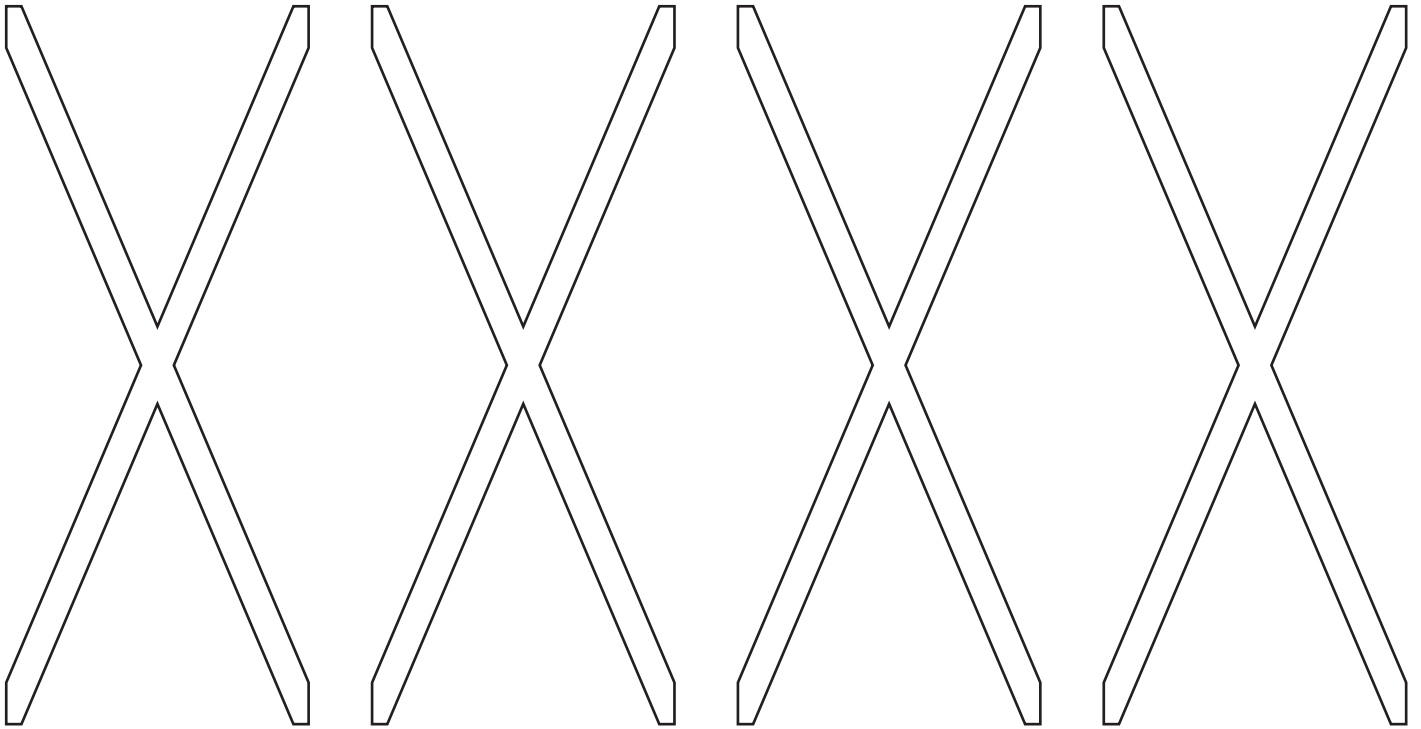

Support Plate

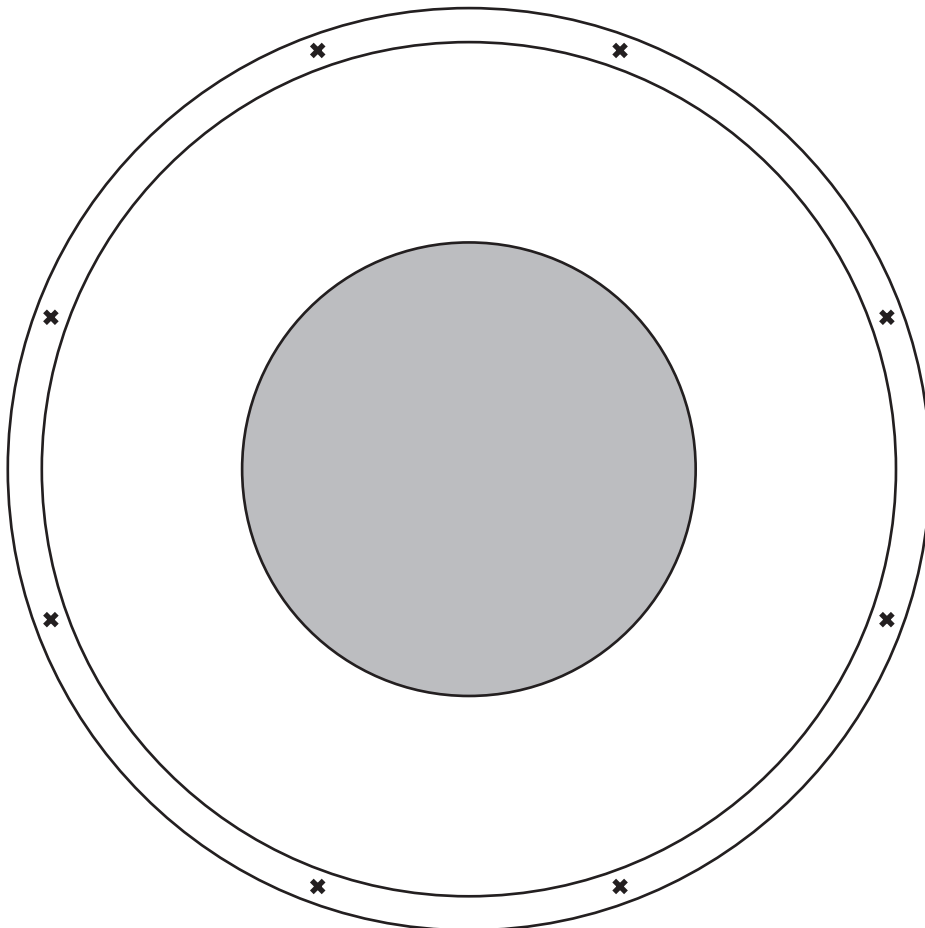

Struts

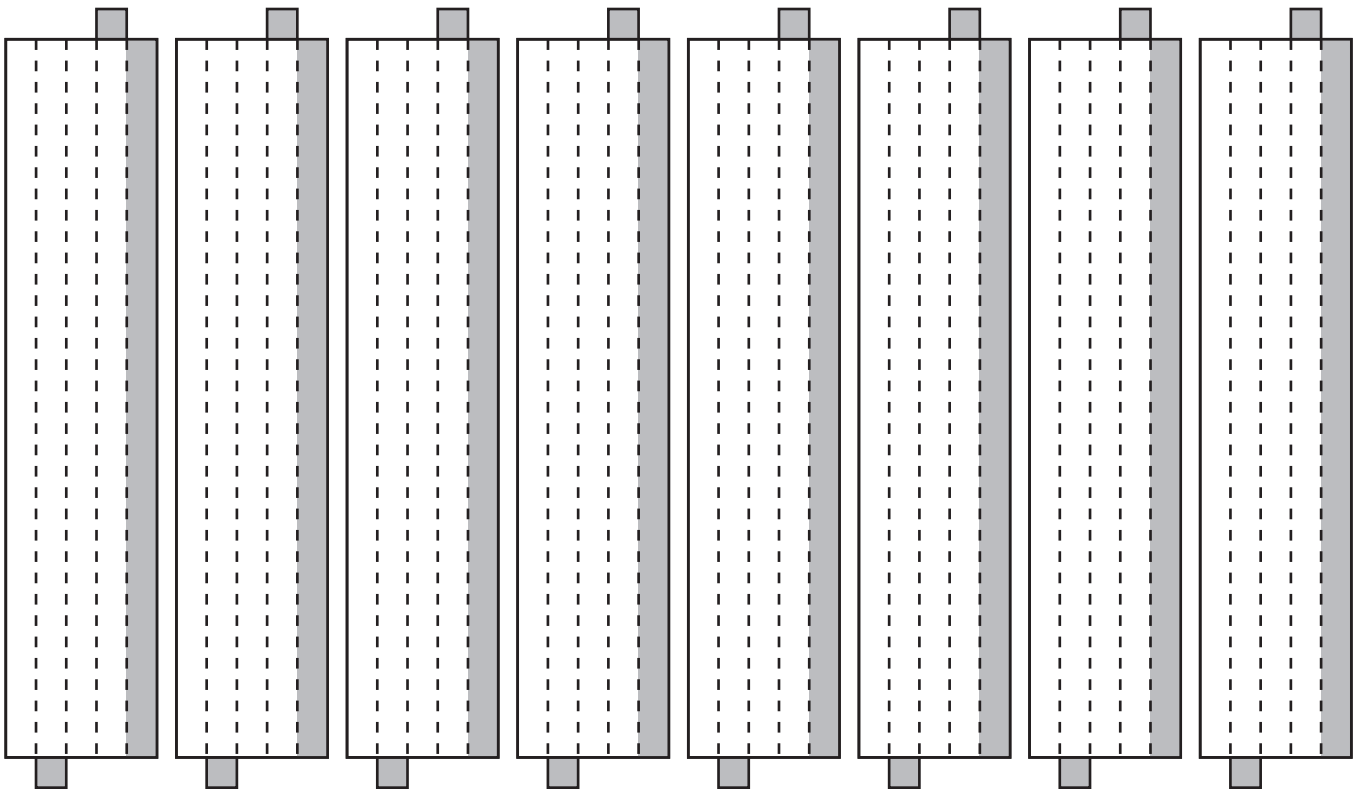
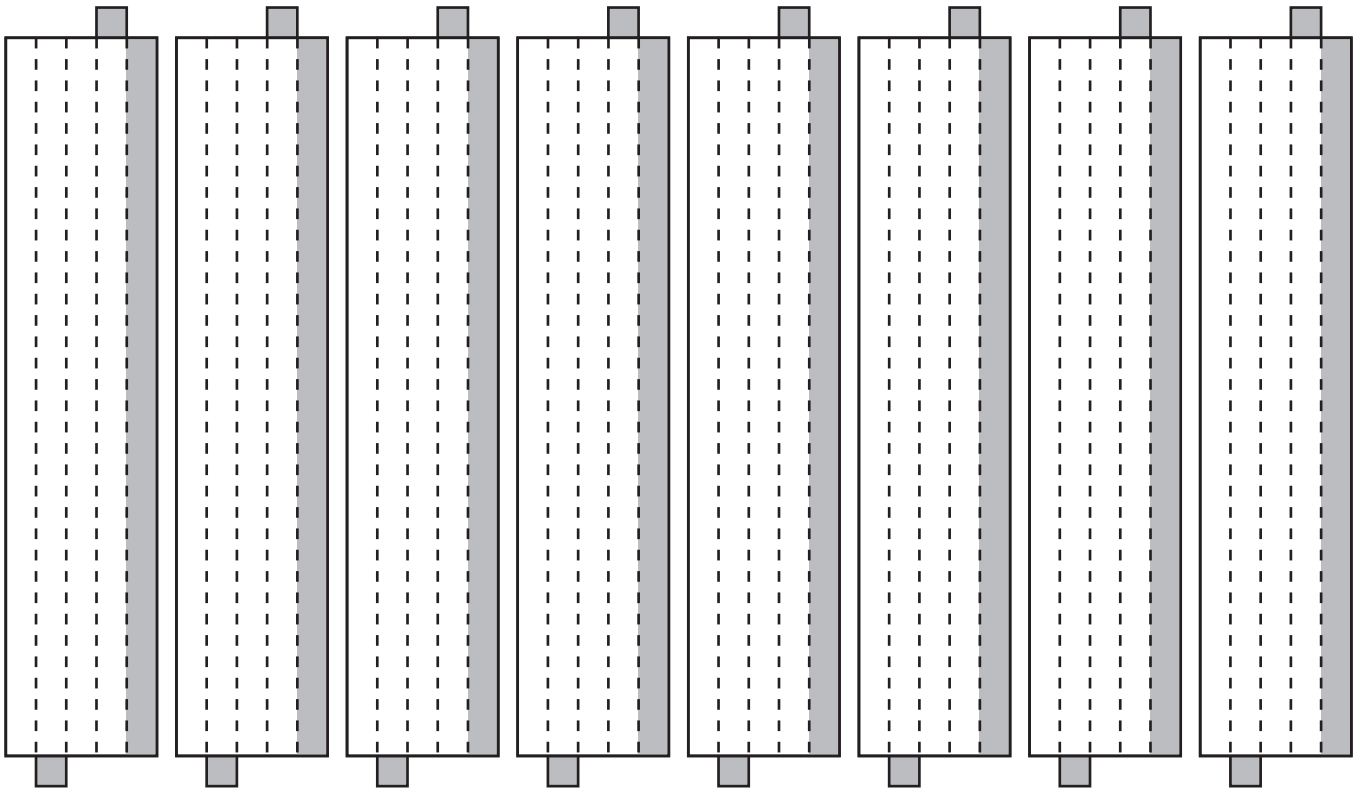

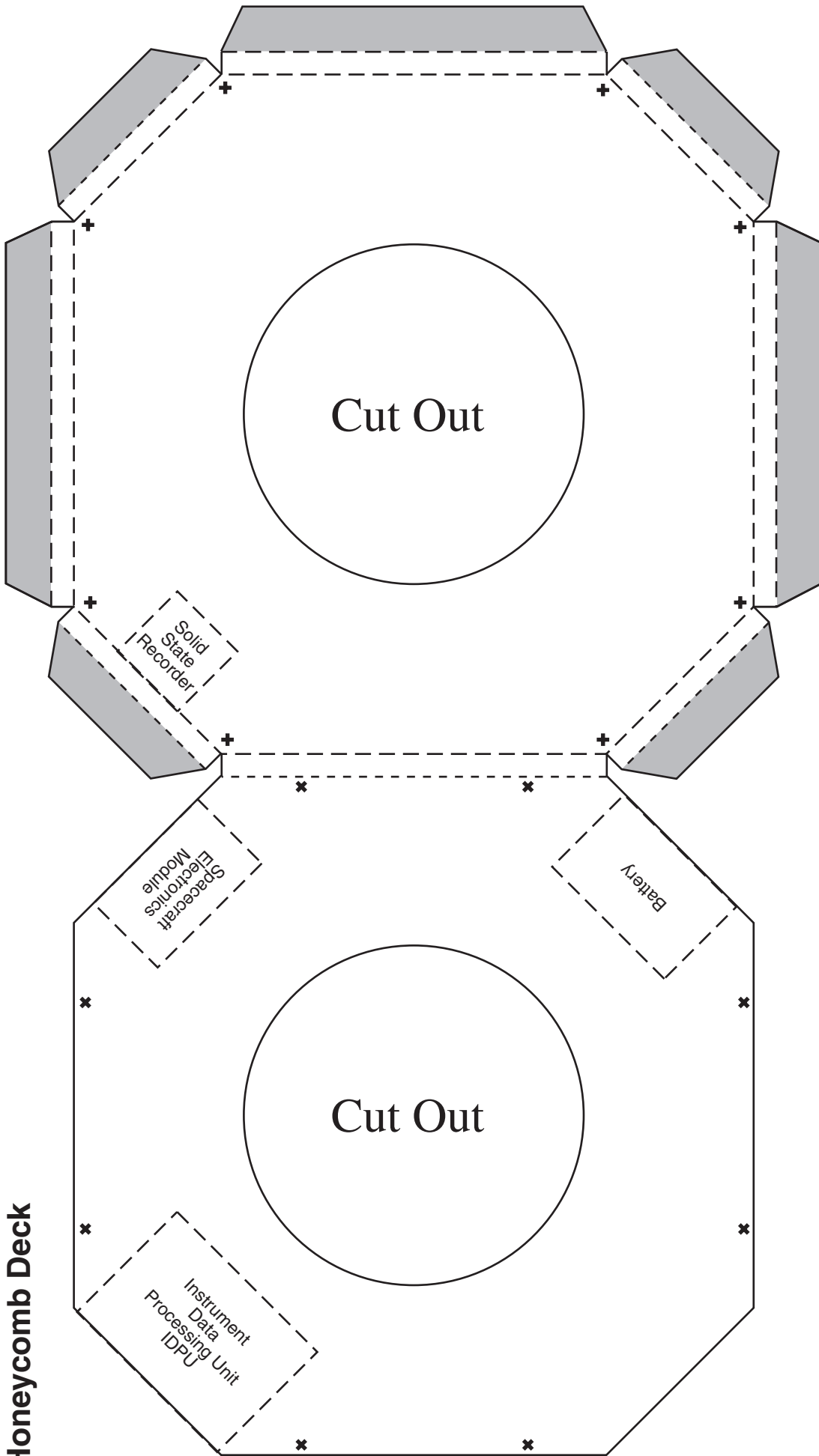

Honeycomb Deck

Top Structure

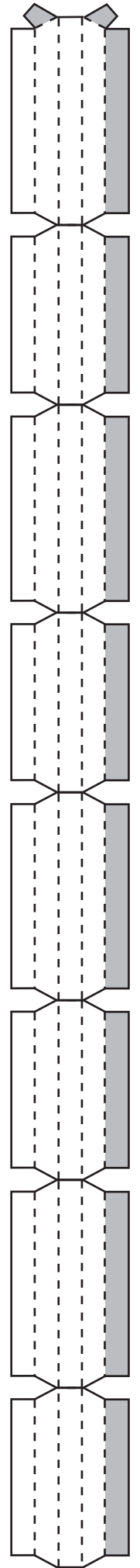

Solar Panels

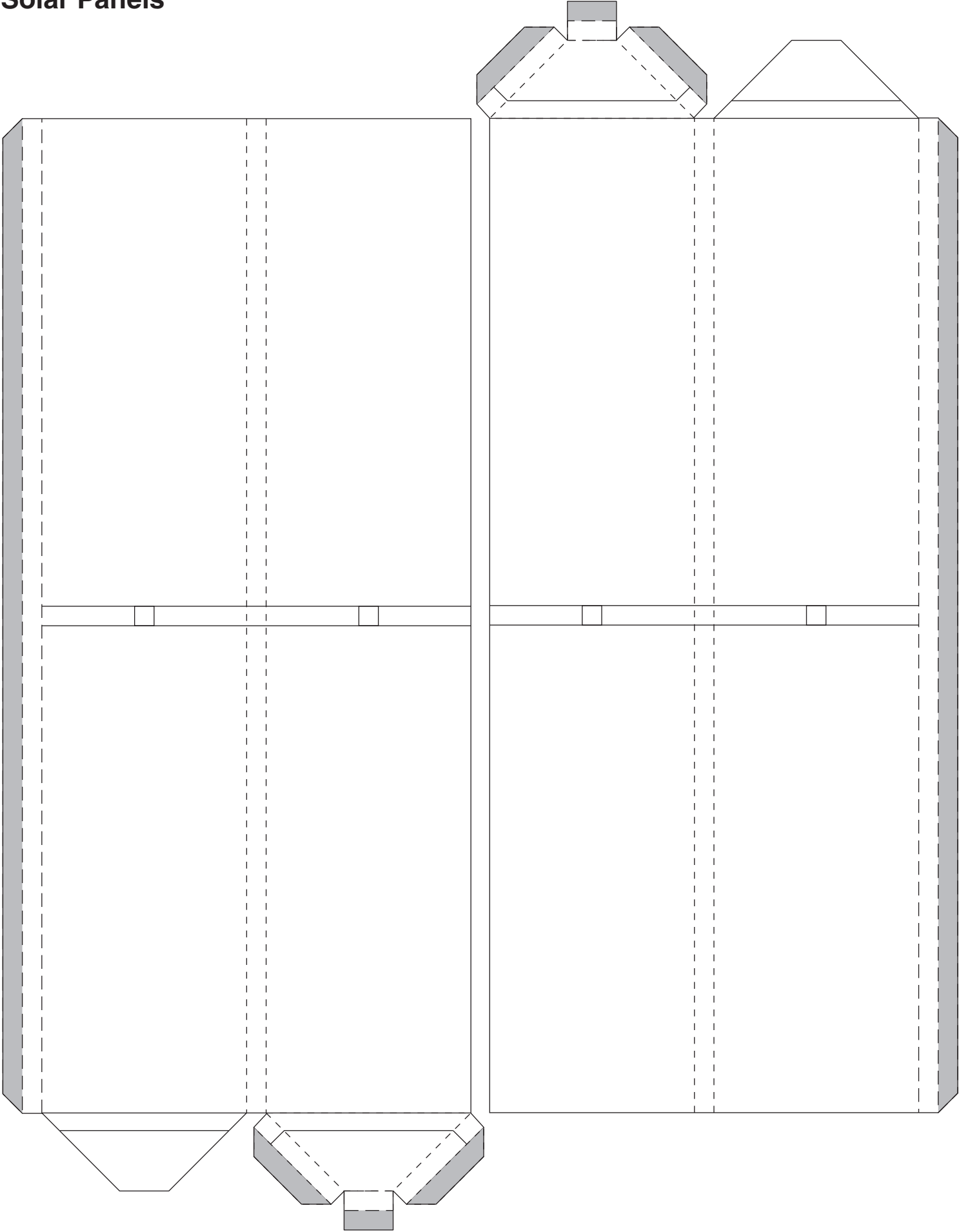

Solar Panels

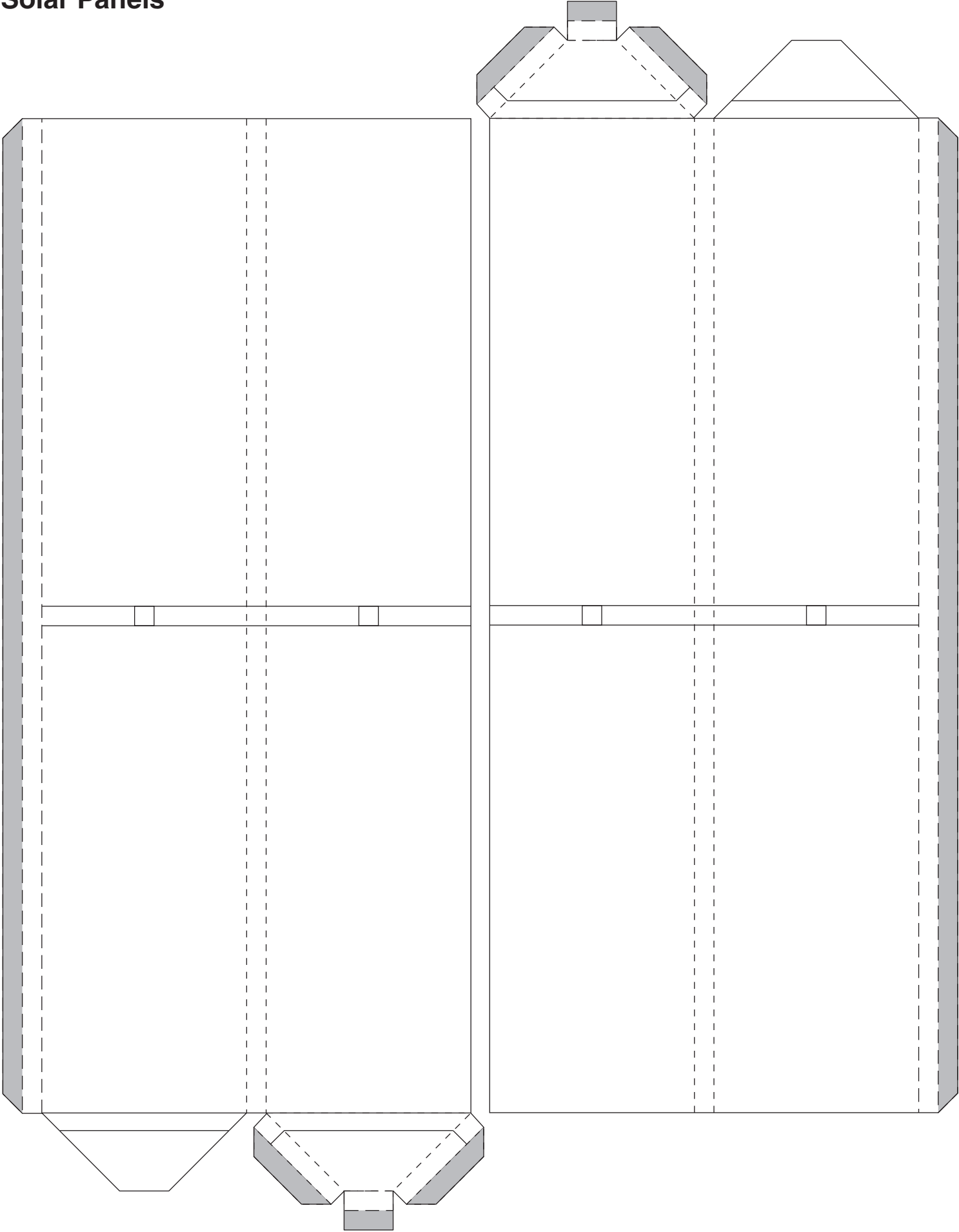

Electronic Modules

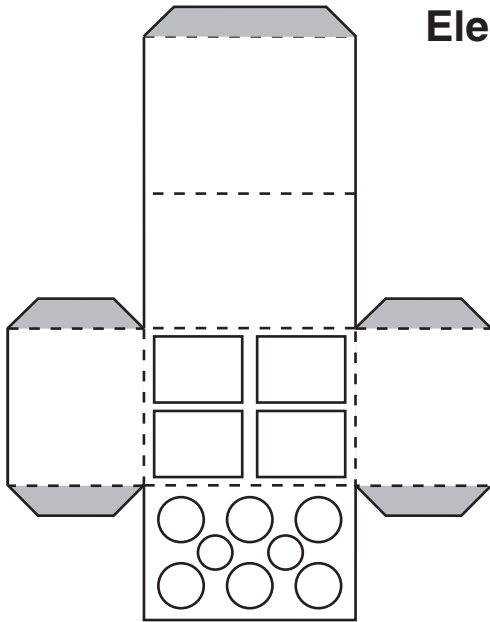

Battery Box

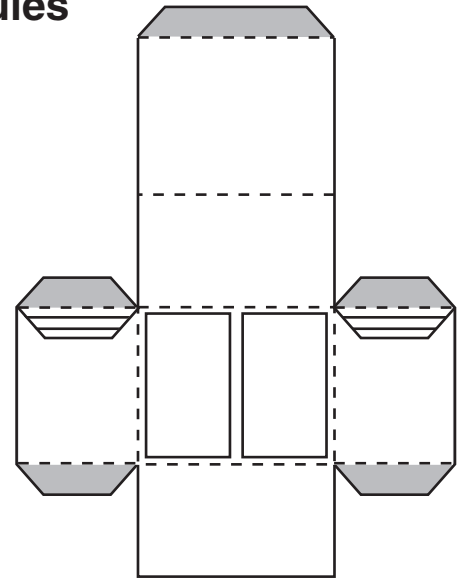

Spacecraft Electronics Module (SEM)

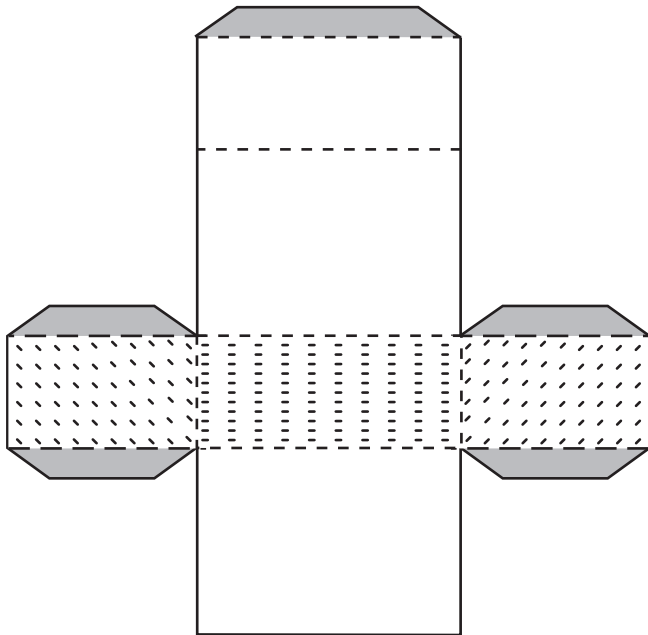

Instrument Data Processing Unit (IDPU)

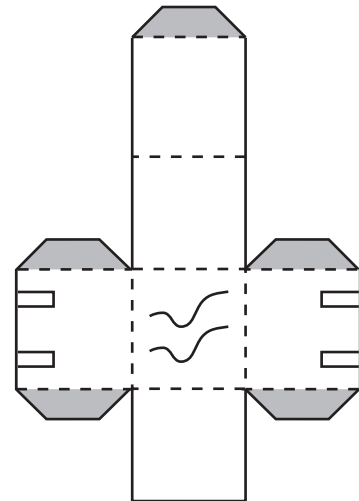

Solid-State Recorder Box

Antennas (2) and Fine Sun Sensor (1)

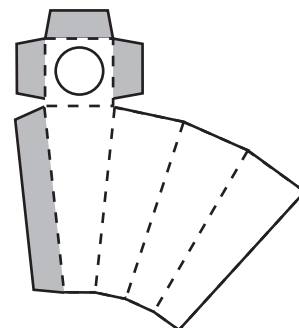
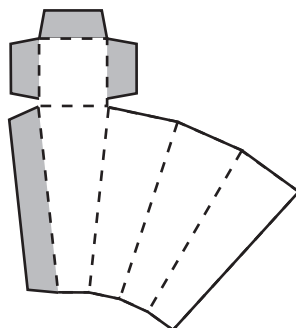
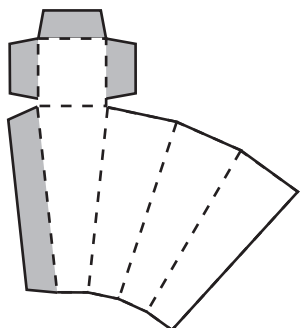

TELESCOPE

DETECTOR HOUSING

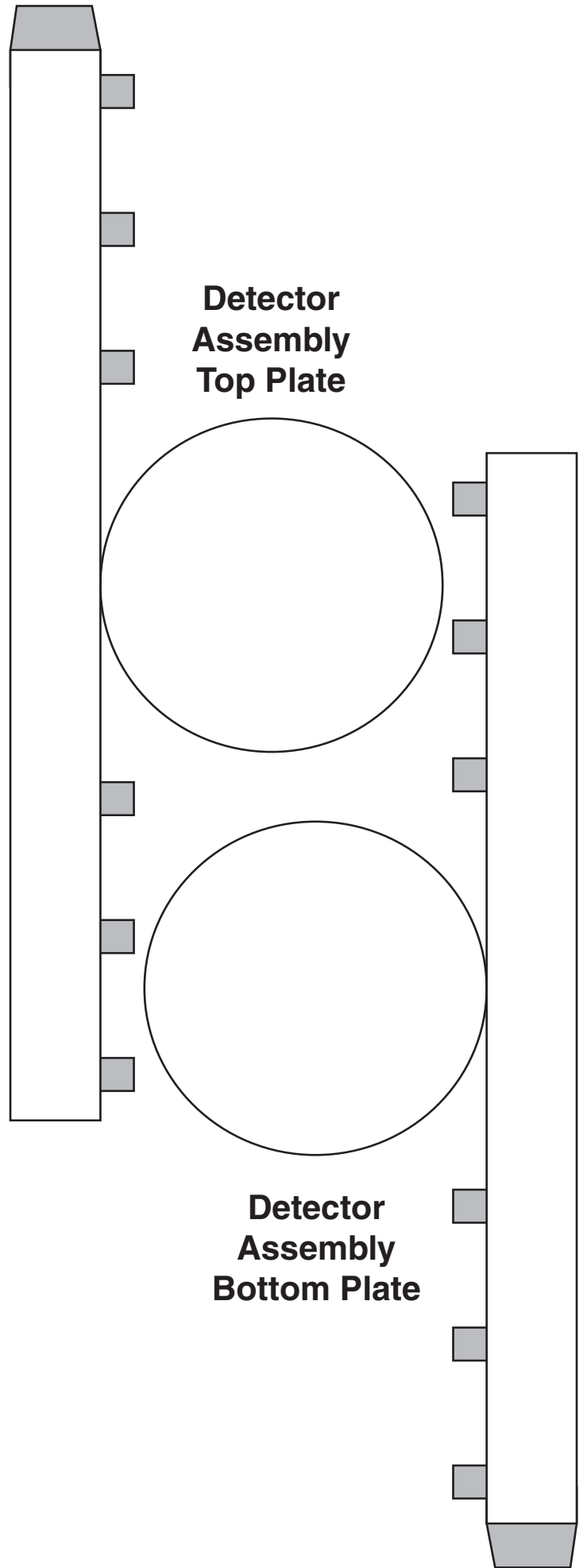
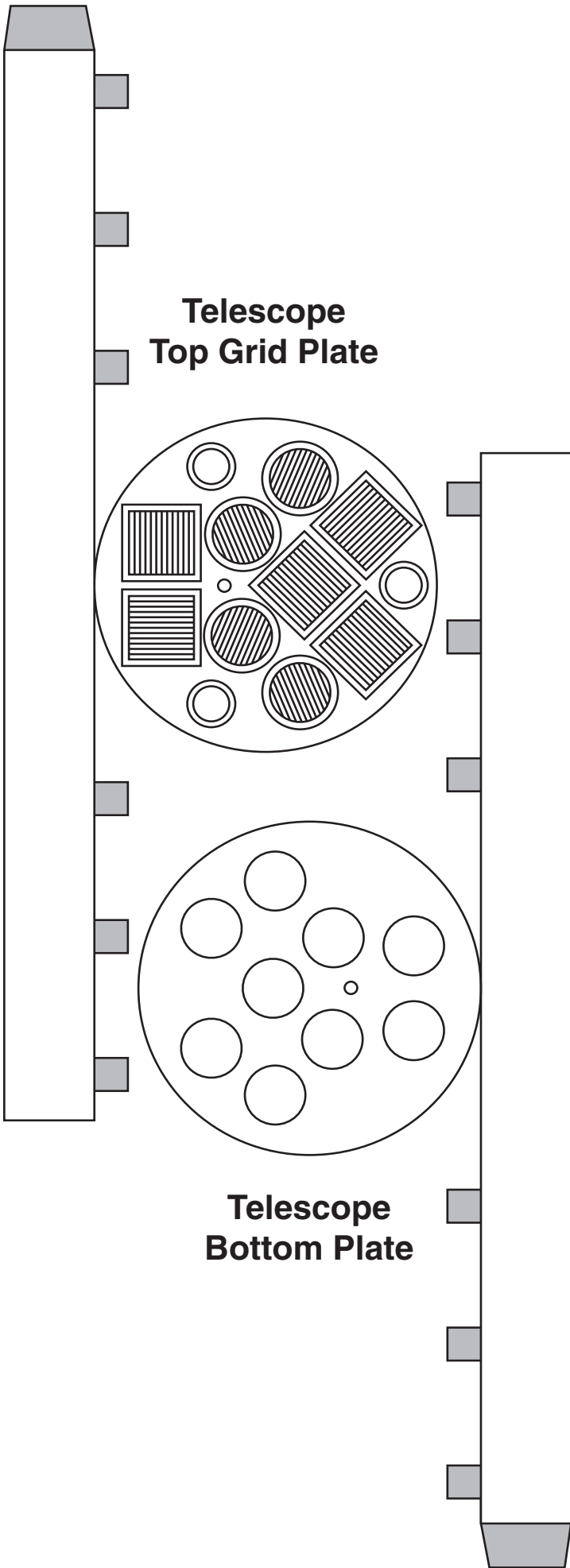

Structural Engineering Team (continued)

Struts (16)

- 1 Cut out the Struts, pg. 5.
- 2 Fold along the dotted lines to make a long square tube with the outermost white section overlapping the shaded area.
- 3 Apply rubber cement on the shaded area.
- 4 Press the cemented areas firmly together.

Cross Members (4)

- 1 Cut out the Cross Members, pg. 3. Glue each Cross Member to two Struts as shown in the lower left corner of Photo 1. They will be used later, during the final assembly.

Top Structure

- 1 Cut out the Top Structure, pg. 7.
- 2 Fold along the dotted lines, making it into the shape you see in Photo 3.
- 3 Apply rubber cement and glue together.

Final Assembly

Now you have all the parts needed to assemble the spacecraft.

- 1 Position the Support Plate on a flat surface.
- 2 Glue the Detector Assembly (Spectrometer) onto the shaded area on the Support Plate.
- 3 Glue the completed Cross Member/Struts structures (you should have 4 of them) by positioning on top of each "x" on the Support Plate. Be sure to have the Cross Members facing outward (see Photo 2). Allow the rubber cement to dry.
- 4 Drop some rubber cement on the upper portion of the Cross Member/Struts structures tabs and place the Honeycomb Deck on top of the Struts (each Strut should be positioned on an "x" on the Honeycomb Deck). Allow the rubber cement to dry.
- 5 Glue the Electronics Modules to the deck by matching the letters and broken lines (see Photo 2).
- 6 Glue the 8 remaining Struts on the top of the Honeycomb Deck. Remember to match the X's with each Strut (see Photo 3).
- 7 Glue the Top Structure to the top of the 8 Struts.
- 8 Glue the Antennas and the Fine Sun Sensor to the edge of the Telescope's Top Grid Plate (see Photo 4).
- 9 Slide the Telescope through the openings in the Top Structure and Honeycomb Deck (Photo 4).
- 10 Use tape to attach the top side of each Solar Panel to the top side of one edge of the Honeycomb Deck. Attach a paper clip to the underside of each Solar Panel so that half of the paper clip is pushed in. Tape the paper clip into place. This should hold the Solar Panels in a horizontal position (Photo 5).

Photos: 1 - All parts assembled; 2 - Lower portion completed; 3 - Lower portion attached to top structure; 4 - Telescope placed inside spacecraft structure; 5 - Completed model.

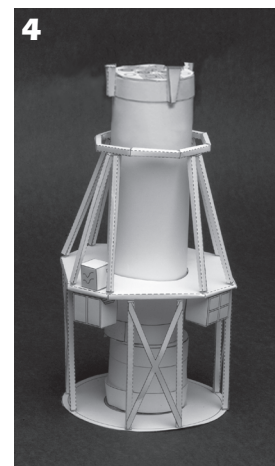
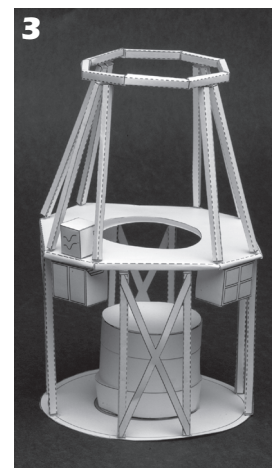
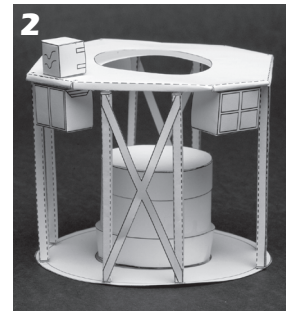
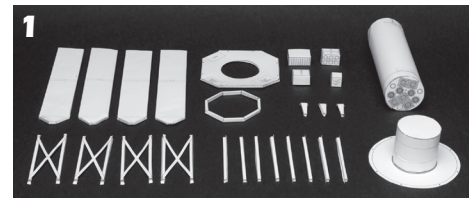

Presentations

After all assembly tasks have been completed, each team will select two members to present 5 minute talks. The talks should include descriptions of what each team has accomplished and what role that team's components play in the HESSI mission.

The Design Team will talk about the colors of the HESSI components.

The gold-colored material on the HESSI structure reflects light from the Sun. This helps to stabilize the temperature of the spacecraft. The blue colored material on the solar panels absorbs sunlight, providing energy to power the spacecraft. The Design Team will also discuss the names of the three layers in the solar atmosphere and how these names are appropriately descriptive.

The Astrophysics Team will talk about the mission of the telescope and the detector.

The HESSI mission consists of a single spin-stabilized spacecraft in a low-altitude orbit inclined 38 degrees to the Earth's equator. The only instrument on board is an imaging spectrometer with the ability to obtain high fidelity "color" movies of solar flares in X rays and gamma rays. It uses two new complementary technologies: fine grids to modulate the solar radiation and germanium crystals to measure the energy of each photon very precisely.

HESSI's imaging capability is achieved with nine grids that modulate the solar X-ray flux as the spacecraft rotates at approximately 15 rotations per minute. The finest grid pair is made of molybdenum and the other eight are made of tungsten. Up to 20 detailed images can be obtained per second. This is sufficient to track the electrons as they travel from their acceleration site, believed to be in the solar corona, and slow down on their way to the lower solar atmosphere, the chromosphere.

The high-resolution spectroscopy is achieved with the germanium crystals. The crystals are cooled to about minus 193 degrees Celsius, which is just 80 degrees above absolute zero (Absolute zero is the lowest temperature possible - when all thermal motion stops!). The cooled germanium detectors, with over 3000 volts across them, provide electrical signals that give a precise measure of the energy of each X-ray and gamma-ray photon transmitted through the grids.

The Electrical Engineering Team will talk about the role of the instruments and how the spacecraft is powered.

The Spacecraft Electronics Module (SEM), the Solid-State Recorder (SSR), and the Instrument Data Processing Unit

(IDPU) have the following functions:

- Command decoding and execution
- Payload data handling
- Telemetry data handling
- Attitude Control System monitoring and control

The solar panels are the source of power for the spacecraft. They convert solar energy into electrical energy used to charge the batteries. There are:

- Four solar panels that are folded up for launch and deployed in orbit
- Batteries and temperature and pressure sensors

The Structural Engineering Team will talk about the need of HESSI to have structural integrity.

The Structural Engineering team will demonstrate the rigidity of the struts, and the necessity of having the spacecraft symmetric and well aligned. The structure includes the aluminum honeycomb deck, the lower struts, the solar array supporting structure, and the cross members. Without it the spacecraft could not hold together in one piece or support its own weight during launch. The structure is the spacecraft skeleton and is used to support the telescope tube and the spectrometer in a stable configuration.

P.S. One student can be on more than one team to provide additional support to a team that requires some help.

For more information about HESSI and solar flares, see the following Web Sites

HESSI at NASA's Goddard Space Flight Center:
<http://hesperia.gsfc.nasa.gov/hessi/>

HESSI at the University of California, Berkeley:
<http://ssl.berkeley.edu/hessi/>

Acknowledgments

The inspiration, the original drawings, and the first physical rendering of this HESSI model were provided by an undergraduate college student, Mr. Iya Massah. Mr. Massah began these efforts when he was a student at Montgomery College, Takoma Park, an ongoing HESSI partner. Mr. Massah's efforts continued even after his graduation from Montgomery College and his matriculation at the University of Maryland, College Park. The HESSI Team is pleased to express its appreciation and admiration for being provided an outstanding mechanism for sharing the intellectual stimulation and excitement of participation in our mission.

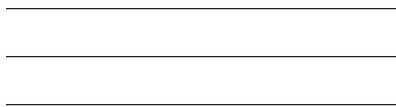

**Postage
Required**

HESSI Model
Code 682
NASA Goddard Space Flight Center
Greenbelt, Maryland 20771